



# VIRTUS®

600 - 1000 W HPS and 1000 W MBI

LAMP COMPARTMENT

IP 65

GEAR COMPARTMENT

IP 65



## RANGE:

A high performance floodlight providing a symmetrical beam for use 1000W HPS and MBI tubular lamps. The fitting is used with remote control gear.

## APPLICATIONS:

Specially suitable for large indoor or outdoor sport stadiums or fascia lighting of very large buildings.

## CONSTRUCTION:

Virtus is made of die-cast aluminium, and it is finish with super thermoset polyester powder coat paint, 2.5 mil. nominal thickness, applied over a chromate conversion coating ; 2500 hours salt spray test endurance rating for outdoor uses.

There is an anodized dimpled high purity (99.85%) aluminium reflector system providing symmetric beam. The protective toughened glass front cover is housed within a die-cast aluminium frame with integral hinge to the body, and incorporates a silicon rubber gasket to provide IP 65 degree of protection.

All external screws are made of stainless steel .

## ELECTRICAL:

The Virtus floodlights has a remote control gear box which can be provided on request. High temperature silicon insulated conductors are used throughout.

## MECHANICAL:

Mounting is via a hot deep zinc coated heavy duty steel bracket incorporated an aiming device.

## SPECIFICATION:

Designed in accordance with relevant European Standards.

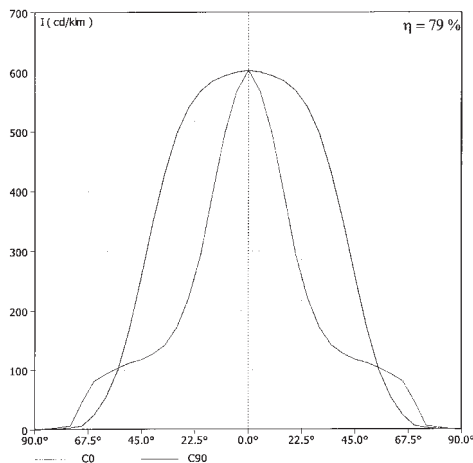
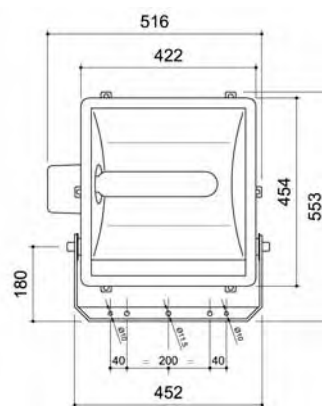
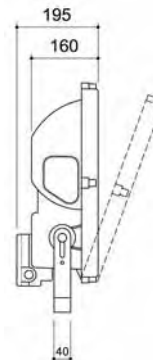

HPS-T 1000W

## ORDERING DATA

CODE N°	LAMP	LAMP HOLDER	WEIGHT KG
NX4970	EMPTY	E40	5,20
NX4972	Empty + ignitor	E40	6,00
NX3454	Wired control gear box 1000W HPS		9,80
NX3455	Wired control gear box 1000W MBI		9,80