



# ARGOS®

LAMP COMPARTMENT  
IP 65 



CORROSION RESISTANT, WEATHER PROOF COMPACT FLOODLIGHT

## RANGE

A highly aesthetic compact corrosion resistant weather proof fitting with integral control gear. Can be used with 70W HPS, 70W/150W HQI, and 80W MBF lamps.

## APPLICATIONS

Particularly suitable for loading areas, building perimeters, precinct areas, building facades, shop signs, and security applications. This is an ENERGY SAVING floodlight which uses 75% less energy than traditional tungsten halogen models, with more than five times longer lamp life.

## CONSTRUCTION

Argos is made of injection moulded, high quality impact resistant self-coloured black or grey (Ral 7035) polycarbonate. The gear compartment is separate from the lamp compartment, thus giving both compartments IP 65 ingress protection. The symmetric reflector is made of anodised aluminium with a dimpled finish. The toughened glass is mounted inside a polycarbonate frame, which is screwed to the body by means of four stainless steel screws. Weather proofing IP65 ingress protection, is attained by a silicon gasket.

## ELECTRICAL

All electrical components are mounted on an easy to remove injection moulded polycarbonate gear tray. High temperature silicon insulated conductors are used throughout. The wiring is accessed via a PG11 compression type cable gland.

## SPECIFICATION

Designed in accordance to the following Standards: CEI 34 -21 and EN60598-1.

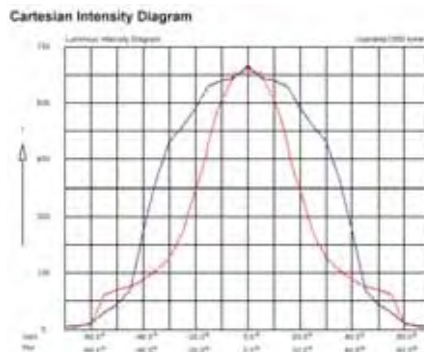
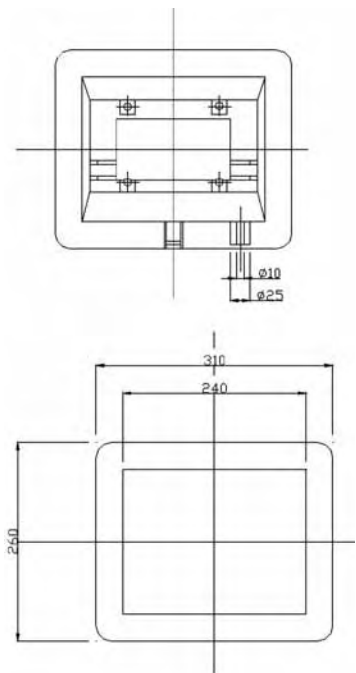

70 W HQI - R7S

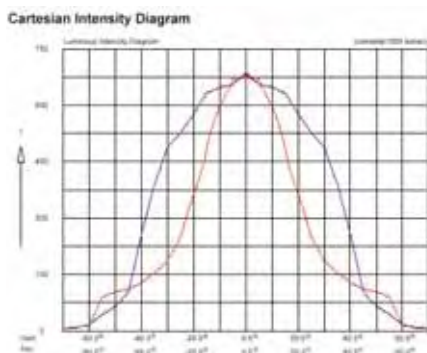

70 W HPS

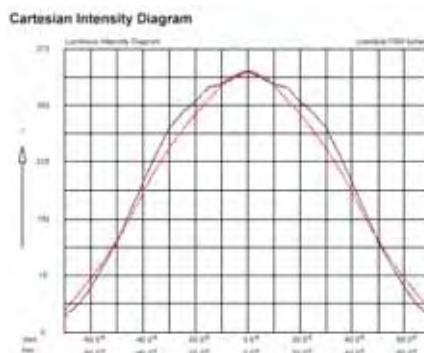

70 W MBI - E27

## ORDERING DATA

CODE N°		LAMP	LAMP HOLDER	WEIGHT KG
BLACK	GREY			
NX 3809	NX 3880	EMPTY	R7S-70	2,00
NX 3801	NX 3891	EMPTY	E27	2,00
NX 3802	NX 3882	EMPTY	R7S-150	2,00
NX 3803	NX 3893	70 W HPS w/o ignitor	E27	3,60
NX 3804	NX 3884	70 W HPS c/w ignitor	E27	3,60
NX 3805	NX 3885	70 W HQI	R7S-70	3,80
NX 3806	NX 3887	150 W HQI	R7S-150	4,70
NX 3808	NX 3889	80 W MBF	E27	3,60