

SOLEX®

RESIDENTIAL

LAMP COMPARTMENT
IP 65



RANGE

Solex® is a high specification, high performance wall pack luminaire suitable for use with a wide range of energy saving HID lamps from 70W/100W/150W HPS, 70W/100W/150W MBI and 80W/125W MBF.

APPLICATIONS

The Solex® luminaire can be used in areas that require optimum vertical illumination with glare control at low mounting heights. Ideal for parking garages, greenhouses, garden centers and low profile industrial aisles and difficult environmental conditions where maximum security is essential. The high performance of this luminaire with all type of energy saving HID lamps, combined with the IP 65 ingress protection provides an ideal luminaire to be used also in exposed areas such as harbour quays, railway stations, service stations, food industries, pharmaceutical industries, steel works and ship yards.

CONSTRUCTION

Housing: is made of rugged, heavy die cast aluminium.

Optics: one piece injection-moulded, 100% virgin clear acrylic. The refractor is attached on the housing by no. 3 stainless steel clips and remains hinged to the housing during maintenance. A special silicon gasket is used between the housing and the refractor.

ELECTRICAL

Control gear is rated 230V or 240V 50Hz as standard. HPS and MBI circuits are fitted with superimposed pulse electronic ignitors as standard, minimizing the possibility of ballast failure in prolonged operation with a failed lamp inserted. A three pole terminal block for mains connection is provided. High temperature silicon insulated conductors are used throughout.

MECHANICAL

Solex® can be directly mounted on the ceiling by the quick-mount attachment plate. The plate is hinged to the fixture housing during installation. Fixture is then twist locked into place and secured in a weather proof installation. Solex® can be also pole or arm mounted. The power supply enters through a PG 13.5 cable gland. The body can be fully opened up and the gear tray completely removed, this guarantees a simple and rapid maintenance operation.

SPECIFICATION

Designed in accordance with the following Standards: CEI 34-21 and EN60598-1

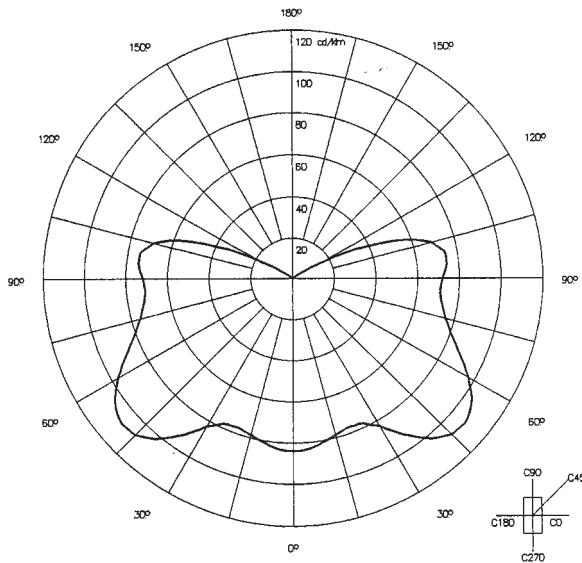
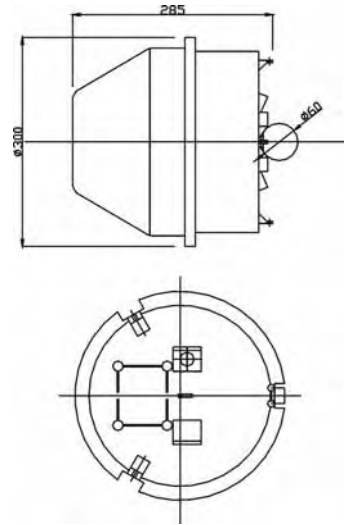

HPS-E 70W

ORDERING DATA

CODE N°	LAMP	LAMP HOLDER	WEIGHT KG
NX 6800	EMPTY	E27	3,39
NX 6801	EMPTY	E40	3,39
NX 6811	70 W HPS w/o ignitor	E27	4,94
NX 6812	70 W HPS c/o ignitor	E27	4,94
NX 6822	150 W HPS	E40	5,98
NX 6833	70 W MBI	E27	4,50
NX 6823	100W MBI	E27	5,88
NX 6834	150 W MBI	E27	6,20
NX 6815	80 W MBF	E27	5,00
NX 6816	125 W MBF	E27	5,88
NX 6003	SPARE PC REFLECTOR		