



PLANET[®]

STREET LIGHTING LANTERN

LAMP COMPARTMENT

IP 65

ELECTRIC COMPARTMENT

IP 54



RANGE:

Decorative pole-mounted luminaires with modern design and additional light outlet at the top. Planet can accommodate 70W HPS, 70W/100W MBI, 80W/125W MBF lamps.

APPLICATIONS:

Planet is suitable for residential streets, shopping streets, gardens, parks, and shopping malls. Recommended mounting heights 3 – 5 m.

CONSTRUCTION:

Cover has been made of formed zinc coated steel, body and three supporting arms are made of die-cast aluminium and the other parts are made of hydroformed steel.

All die-cast and metal parts are finished with super thermosetting polyester powder coat paint, 2.5 mil. nominal thickness, applied over a chromate conversion coating; 2500 hours salt spray test endurance rating for outdoor uses.

The enclosure is made of extruded UV stabilized polycarbonate.

All screws(hard ware) are stainless steel.

The die-cast aluminium spigot is of 60mm diameter.

ELECTRICAL:

Control gear plate is placed between the master spigot and upper body easily accessible for maintenance.

SPECIFICATION

Designed in accordance with the following Standards: CEI 34-21 and EN60598-1

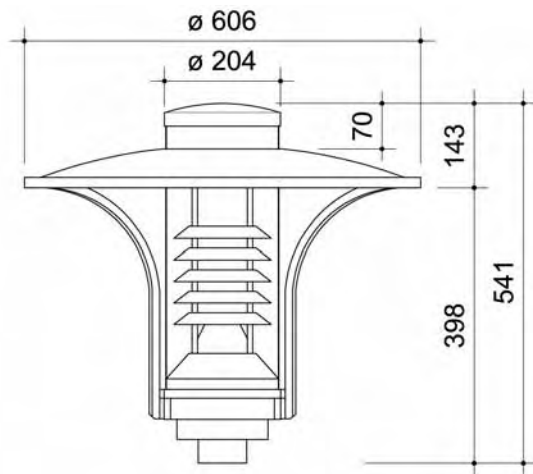

ORDERING DATA

CODE N°	LAMP	LAMP HOLDER	WEIGHT KG
NX 7400	EMPTY	E27	4,00
NX 7401	70W MBI	E27	6,90
NX 7402	100W MBI	E27	7,80
NX 7403	70W HPS w/o ignitor	E27	6,90
NX 7404	70W HPS c/w ignitor	E27	6,90
NX 7405	80W MBF	E27	6,90
NX 7406	125W MBF	E27	7,70