



# LUNIS®

MINI HIGH-BAY

LAMP COMPARTMENT  
IP 23



## RANGE

The LUNIS® luminaire is suitable for use with a wide range of HID lamps including 70W HPS 70W/100W/150W MBI and 80W/125W MBF lamps.

## APPLICATIONS

An attractive, mini low bay luminaire which complements any interior space such as shops, boutiques, restaurants, small work shops, green houses and when used with special lamps it is suitable for growing plants indoors where there is very little natural light.

## CONSTRUCTION

The body is made of extruded aluminium and finished in durable powder coated polyester black paint. The 99.8% purity anodized aluminium reflector is fixed to the body via the polycarbonate shell. The aluminium reflector could also be supplied with tempered protective glass, fixed to the reflector by stainless steel hooks, thus a special silicon rubber gasket is used between the glass and the reflector.

## ELECTRICAL

The zinc coated gear tray is supplied with a three poles terminal block. High temperature silicon insulated conductors are used throughout.

## ACCESSORIES

Tempered glass: the manufacturer of some multi-vapour lamps recommend that a tempered glass cover be fitted to protect against fragments should a lamp fracture.

## SPECIFICATION

Designed in accordance with the following Standards: IEC 598 - CEI 34-21.

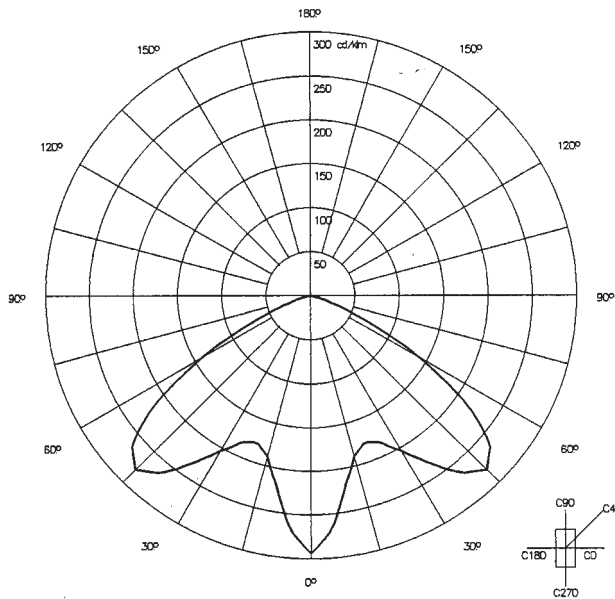
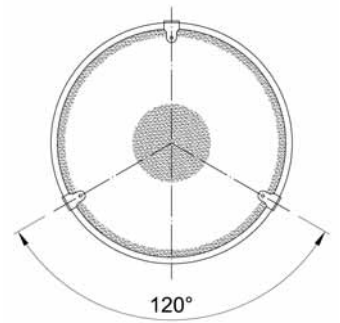
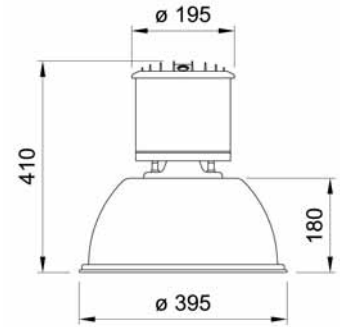

HPS-E 70W

## ORDERING DATA

CODE N°	LAMP	LAMP HOLDER	WEIGHT KG
NX 5427	EMPTY	E27	3,90
NX 5431	70 W HPS c/w ignitor	E27	6,10
NX 5433	70 W HPS w/o ignitor	E27	6,05
NX 5441	70 W MBI	E27	6,10
NX 5442	100 W MBI	E27	6,30
NX 5443	150 W MBI	E27	7,10
NX 5471	80 W MBF	E27	6,05
NX 5473	125 W MBF	E27	6,20
NX 5401	TEMPERED GLASS		1,80

LUNIS

HIGH-BAY / LOW BAY LUMINAIRES